

MINERAL INSULATED RADIANT HEATING CABLE ASSEMBLY

One Conductor and Two Conductor

Mineral insulated (MI) cable consists of one or two conductor heating elements embedded in highly compressed magnesium oxide covered by a copper sheath. Application requirements determine resistance size and sheath material.

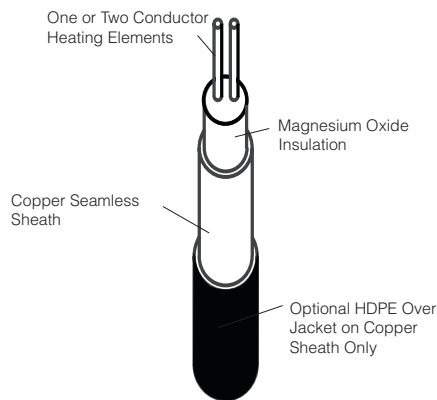

TERMINATION CONSTRUCTION

Each Delta-Therm MI cable assembly is fully terminated and moisture proof. The end termination consists of a 2.5' (76 cm) thermal gradient section connected to 20' (6 m) THWN cold leads. The cold leads are crimped and soldered to the thermal gradient section, insulated with a high-dielectric, high-temperature tape, and epoxy potted in a rigid brass sleeve. The thermal gradient section is silver soldered to the heating element and protected by a rigid brass sleeve packed with magnesium oxide.

COLD LEADS

The 19-strand THWN wire connects to an electrical circuit. Standard cold lead length is 20' (6 m). Leads can be ordered at any length.

NUMEROUS VOLTAGES

Delta-Therm can design MI radiant heating cable assemblies for any voltage up to 600 volts.

FLEXIBLE

MI cable is annealed (annealing tempers metal and removes brittleness) and easy to form and install. Irregular areas and obstacles are easily accommodated.

FLOOR MATERIALS

MI cable can be installed in most common flooring materials.

HDPE JACKETING

Extruded, high-density polyethylene jacketing adds physical strength and protects against corrosives and abrasions.

FIRE RESISTANT

MI cable construction will not contribute to or cause an electrical fire. No Degradation

Delta-Therm MI cable is made of inorganic materials. Degradation of MI cable is negligible when compared to cables made of organic materials such as plastic.

ONE CONDUCTOR CABLE ASSEMBLY

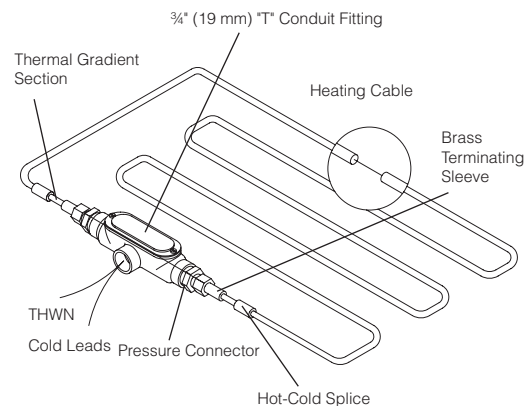

TWO CONDUCTOR CABLE ASSEMBLY

