

MINERAL INSULATED PERMAFROST PREVENTION CABLE ASSEMBLY

One Conductor and Two Conductor

Mineral insulated (MI) cable consists of one or two conductor heating elements embedded in highly compressed magnesium oxide covered by a copper or an Alloy 825 stainless steel sheath. Application requirements determine resistance size and sheath material.

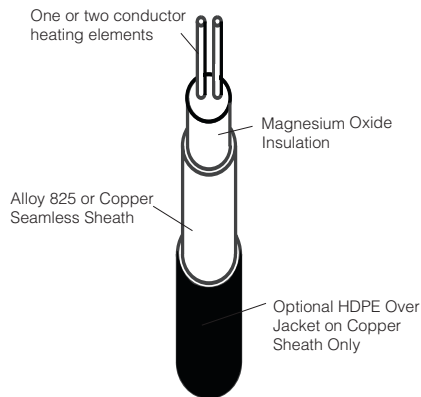

TERMINATION CONSTRUCTION

Each Delta-Therm MI cable assembly is fully terminated and moisture proof. The end termination consists of a 3' (91 cm) thermal gradient section connected to 20' (6.1 m) THWN cold leads. The cold leads are crimped and soldered to the thermal gradient section, insulated with a high-dielectric, high-temperature tape, and epoxy potted in a rigid brass sleeve. The thermal gradient section is silver soldered to the heating element and protected by a rigid brass sleeve packed with magnesium oxide.

COLD LEADS

The 19-strand THWN wire connects to an electrical circuit. Standard cold lead length is 20' (6.1 m). Leads can be ordered at any length, allowing junction boxes to be placed in remote, dry locations.

NUMEROUS VOLTAGES

Delta-Therm can design MI permafrost prevention cable assemblies for any voltage up to 600 volts.

ONE CONDUCTOR CABLE ASSEMBLY

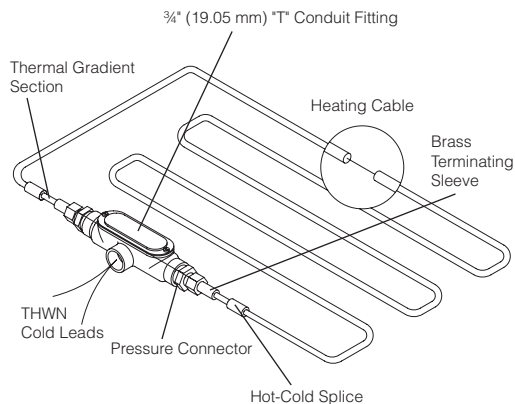

FLEXIBLE

MI cable is annealed (annealing tempers metal and removes brittleness) and easy to form and install. Irregular areas and obstacles are easily accommodated.

HDPE JACKETING

Extruded, high-density polyethylene jacketing adds physical strength and protects against corrosives.

FIRE RESISTANT

MI cable construction will not contribute to or cause an electrical fire.

NO DEGRADATION

Delta-Therm MI cable is made of inorganic materials. Degradation of MI cable is negligible when compared to cables made of organic materials such as plastic.

TWO CONDUCTOR CABLE ASSEMBLY

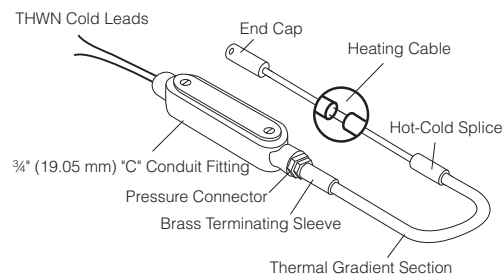

COMPREHENSIVE FACTORY TESTING

Each cable undergoes hi-pot, megger, and resistance tests both before and after overnight immersion in water.

LOW INSTALLATION COSTS

MI cable arrives ready to install. Since terminations are done at the factory, electricians can expedite the installation, helping to reduce overall installation costs.

RECOMMENDED WATTS PER LINEAL FOOT AND CABLE SPACING

Area	Watts	Centers
freezer floor	4-12 watts	4" (122 cm) centers

MATERIAL TEMPERATURE LIMITS

HDPE Overjacket	194 °F*
Copper	392° F (90° C)

*HDPE overjacketed cable may be exposed to higher temperatures during installation in asphalt.

COLD LEAD SIZE

Amps	Wire Size
0-16	12 AWG
16-24	10 AWG
24-45	8 AWG
45-65	6 AWG

BASE KIT (supplied w/each MI cable assembly)

- Three Foot Thermal Gradient Section
- Cold Leads
- Pressure connectors
- "T" or "C" Condulet w/Gasket and Cover
- Delta Dry (water repellent powder)
- Ductseal
- Installation Instructions

ACCESSORIES

- Heater assembly only
- Additional 19-strand cold lead
- Base kit
- Splice kit
- Unilet kit
- Additional thermal gradient
- Fiberglass Tape
- Aluminum Tape
- Monitor Lights
- Caution Lables

CONTROLS

- OTS-F1** Ambient or Line Sensing Thermostat
- A419ABC-1** Electronic Line Thermostat and Display
- A419AEC-2C** Electronic Line Thermostat and Display

PANELS

- Enclosed Contactor
- GFPE Power Relay Panel
- Custom Control/Monitor Panels

INVENTORY & SHIPPING

Delta-Therm maintains an inventory of both bare and jacketed mineral insulated cable. Orders of material in stock can usually be shipped within two weeks.

To Order:

Prefix (T - Tube)																			
Number of Conductors																			
Ohms/ft. (m)																			
Length per Hot Section																			
Volts																			
Amps																			
kW																			
Watts per Lineal Foot (see design guide)																			
Suffix H, B, or SS (if desired)																			
AWG (see chart)																			
Cold Length (length needed to reach junction box)*																			

* voltage drop not to exceed 3%



398 W. Liberty St. P.O. Box 345 Wauconda, IL 60084
 (800) 526-7887 (847) 526-2407 (312) 346-0053 FAX (847) 526-4456
 Email heat@delta-therm.com Internet http://www.delta-therm.com