

ICE MELT PANELS (IMP) ▲

Angled And Flat Ice Melt Panels



Angled IMP

Flat IMP

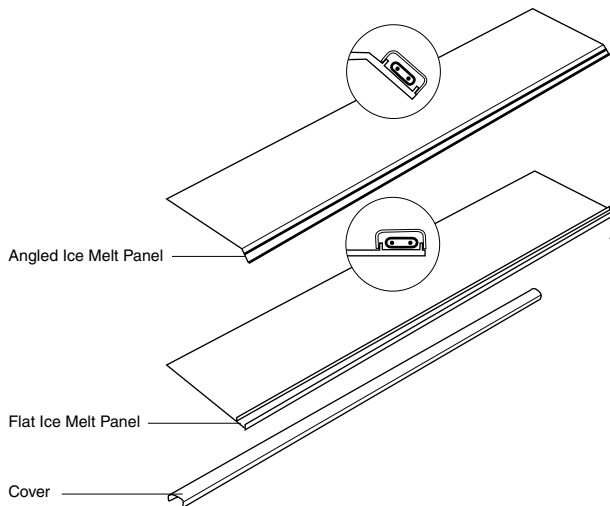

Detail 1. Flat and Angled Ice Melt Panels

DESCRIPTION

The Ice Melt Panels are designed to warm the roof edge in order to prevent ice dams.

The panels can contain either the Delta-Therm CO or IN series of self regulating roof deicing cables.*

The Ice Melt Panels are L/W 4'8" (1m/20cm) and are installed along the roof edge between the waterproof membrane and the shingle.

FEATURES

- Panels Are Made Of Aluminum
- Roof Deicing Cables Are Inserted Into The Cable Channel
- Shingles Are Installed On Top Of The Panel, Only The Cable Channel Is Visible
- Panels Can Be Painted To Match The Shingle Color
- Panels Are L/W 4'8" (1m/20cm) With A Cable Channel
- Panels With A Slanted Cable Channel Mount Along The Roof Edge
- Panels With A Flat Cable Channel Mount Above The Roof Edge And Along The Inside Of The Valleys

INSTALLING

1. Panels are installed .25" (.64cm) apart to allow for the natural expansion and contraction of the roof. The panels are attached using screws or nails.
2. Install one or two rows of panels to cover the roof area 6" (15cm) past the roof overhang.
3. Install cables inside of gutters and downspouts to provide a heated path for melt water to completely drain off of the roof.

*CO and IN Series cables are sold separately.

CUTTING THE ICE MELT PANELS

1. The Ice Melt Panels are supplied in 4' (1m) lengths and can be cut to length in the field. After cutting, debur the panel edges and channel cover edges.

INSTALLING THE ICE MELT PANELS

1. On existing roofs, carefully peel back the asphalt shingles, exposing the roof substrate to accommodate the Ice Melt Panel. Refer to Detail 2.
2. On new roofs, install the panels on top of the rubber membrane before installing the asphalt shingles. Refer to Detail 3.
3. Drill mounting holes anywhere in the hatched area of the panel. Refer to Detail 4.
4. Using screws, attach the Ice Melt Panel to the roof substrate. Do not screw down tightly because you may need to readjust alignment of the channels when you install the deicing cable.
5. Allow .25" (.64cm) spacing between the flashings to allow for expansion and contraction of the aluminum. Refer to Detail 6.
6. Clean the channel area before installing the deicing cable to remove any debris.
7. Install the deicing cable inside of the channel. Refer to Detail 7.
8. Position the channel cover by fitting the top barb first.
9. Snap the cover down onto the bottom bar. You can use a rubber mallet to install the cover on the flat panel channel. You can use an offset pump pliers to install the cover on the angled panel channel.
10. Tighten screws down on all panels when complete.

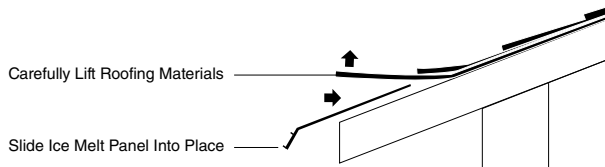

Detail 2. Installing the Ice Melt Panel on an existing roof.

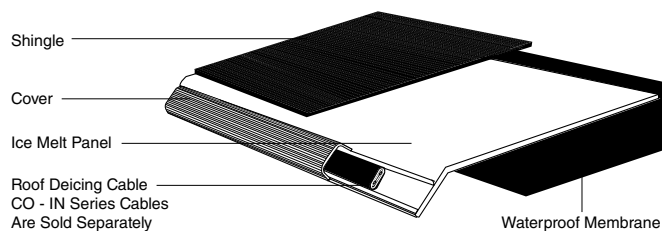

Detail 3. Installing the Ice Melt Panel on an existing roof.

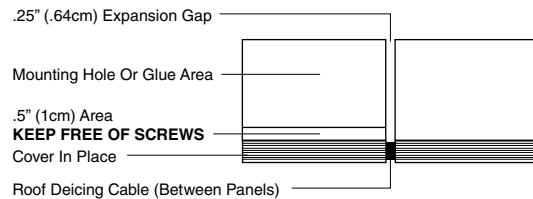

Detail 4. Do not drill mounting holes within .5" (1cm) of the channel.

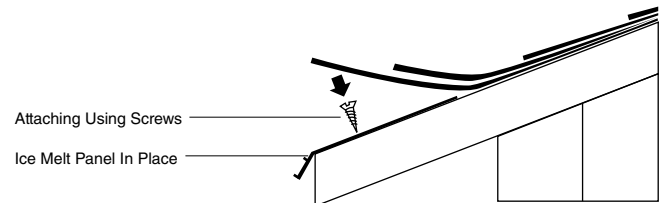

Detail 5. Screw the Ice Melt Panel into place.

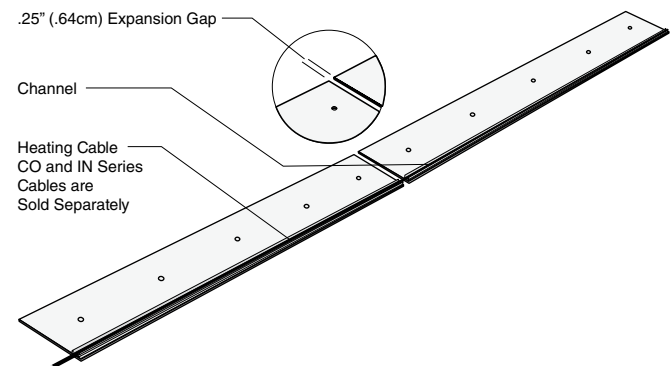

Detail 6. Leave .25" (.645cm) expansion/contraction joint between each panel.

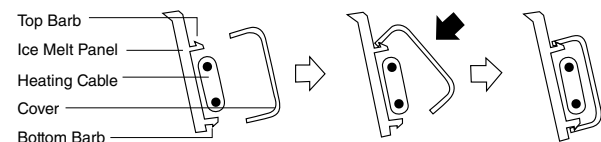

Detail 7. Install the cable and channel cover.

TECHNICAL SUPPORT

A full set of installation instructions is included with order. Please call 1-800-526-7887 with any questions.