



Installation Instructions

MPS SNOW MELTING AND ROOF DE-ICING CONTROLS



MPS W/RG Roof and Gutter or Snow Melting Control



MPS W/MMP Roof and Gutter De-icing or Snow Melting Control



MPS W/MP Roof and Gutter De-icing or Snow Melting Control

CONTENTS	page
SECTION 1. OVERVIEW	
1.1 Precautions.....	2
1.2 Base model components.....	2
1.3 General accessories.....	2
1.4 Operation.....	2
SECTION 2. INSTALLING	
2.1 Installing the MPS control panel	3
2.2 Electrical connections when MPS is switching load	3
2.3 Electrical connections when contactor panel is switching load.....	5
2.4 Installing the RG roof sensor	6
2.5 Installing the MP slab sensor.....	7
2.6 Installing the MMP sensor	8
2.7 Installing the RID	9
SECTION 3. TESTING AND TROUBLE SHOOTING	
3.1 Maintenance	10
3.2 System function test	10
3.3 Trouble shooting and Technical Support	10

Section 1. Overview

1.1 PRECAUTIONS

- Installation must comply with local electrical codes.
- All related components and this control should be properly rated for the specified location classification.
- The control must be installed by a qualified electrician.
- The MPS control panel enclosure is rated NEMA 4 and must be located appropriately.

1.2 BASE MODEL COMPONENTS

MPS W/RG	MPS W/MP	MPS W/MMP
(1) MPS Control Panel	(1) MPS Control Panel	(1) MPS Control Panel
(1) RG Sensor	(1) MP Sensor	(1) MMP

1.3 GENERAL ACCESSORIES

Accessories

Product Number	Description
RGS	Secondary moisture sensor for MPS W/RG or MPS W/MP
SMMP	Secondary moisture sensor for MPS W/MMP
R.I.D.	Remote indication and activation timer
MPSWP-50	plenum rated six conductor #22 AWG sensor extension wire
MPSW-50	non-plenum rated six conductor #18 AWG sensor extension wire
RSW-50	RID extension wire

1.4 OPERATION

The MPS (120 VAC) is intended to control heating cable in the application of slab snow melting or roof and gutter de-icing. The MPS control panel receives low voltage input from an external slab or gutter sensor(s), thermistor, and/or RID (remote indication device with timer).

The snow melting or roof de-icing system will activate when the following two conditions are met:

1. The slab/ambient temperature is less than the set point of 40°F (4.4°C).
2. Snow or moisture is present on the moisture sensor.

Once these conditions are met, the snow melting or roof de-icing system remains activated for 5 hours (snow melting) or 75 minutes (roof de-icing) after one of the two conditions ceases. The snow melting or roof de-icing system then deactivates and remains deactivated until the two conditions reoccur.

Section 2. Installation

2.1 INSTALLING THE MPS CONTROL PANEL

The MPS control panel can be installed outdoors or indoors. Mount the MPS control panel horizontally with the door hinge underneath (the door should swing down to open). Mount the panel using attachment method appropriate for the surface.

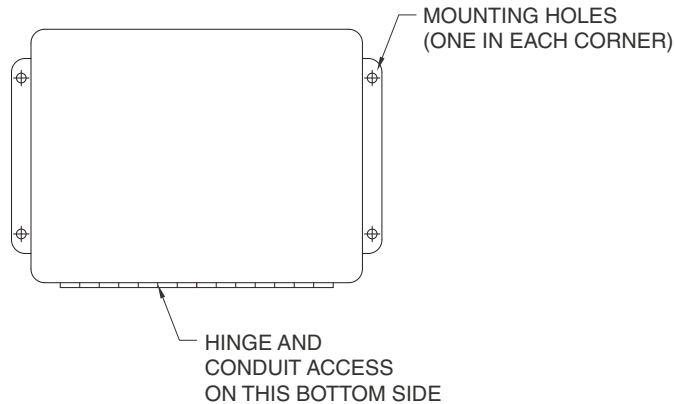

Detail 1. Installing MPS control panel.

2.2 ELECTRICAL CONNECTIONS WHEN MPS IS SWITCHING LOAD

1. Connect 1/2" (13mm) conduit for line voltage in the pre-punched hole on the bottom right of the control panel.
2. If the MPS is switching the heating cable directly route either 120, 208, or 240 VAC line, neutral, and ground wires through the conduit to the MPS control panel.
3. Connect 1/2" (13mm) conduit in the pre-punched hole on the bottom right and route power to the heating cable.

NOTE: The MPS requires a neutral with any supply voltage. The MPS switches power on one current carrying conductor only.

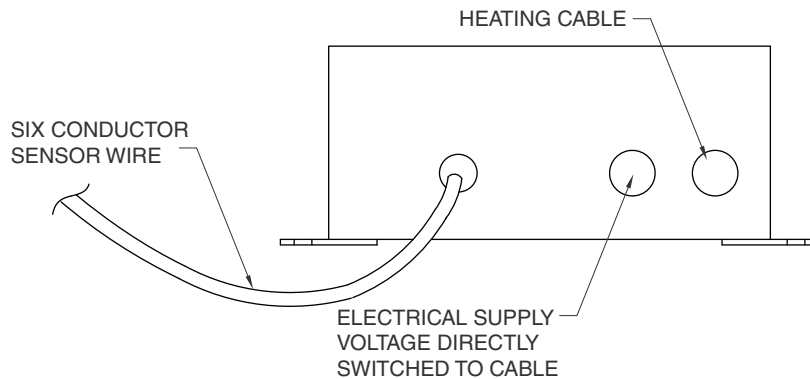

Detail 2. Electrical connection when the MPS is switching load.

Section 2. Installation

2.2 ELECTRICAL CONNECTIONS WHEN MPS IS SWITCHING LOAD

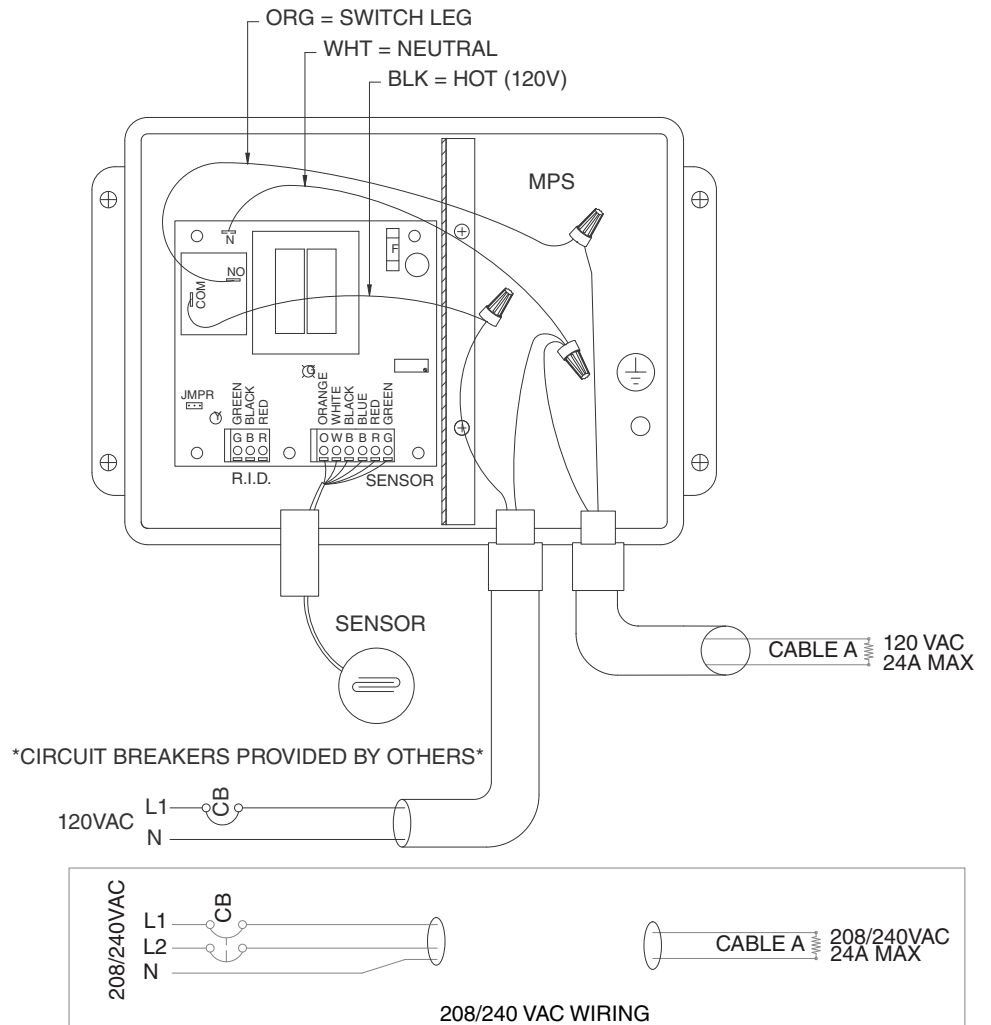

Detail 3. Electrical wiring when MPS is switching load.

Section 2. Installation

2.3 ELECTRICAL CONNECTIONS WHEN CONTACTOR PANEL IS SWITCHING LOAD

1. Connect 1/2" (13mm) conduit for line voltage in the pre-punched hole on the bottom right of the control panel.
2. Route either 120, 208, or 240 VAC line, neutral, and ground wires through the conduit to the MPS.
3. Seal any unused conduit opening in the MPS with an appropriate knock-out plug.
4. Use the orange #10 AWG lead wire in the MPS as the switch leg for the contactor coil(s).
5. Route the wiring as necessary for switching power to the contactor(s).

NOTE: The MPS requires a neutral with any supply voltage.

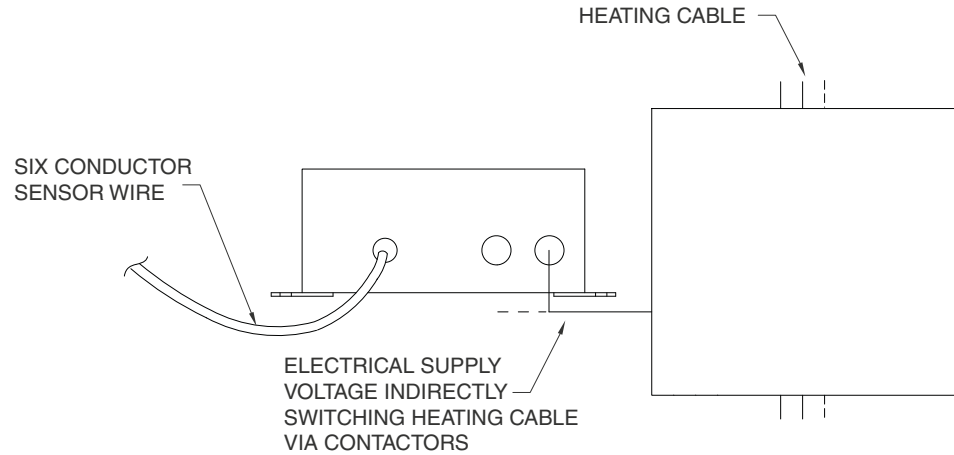

Detail 4. Electrical connection when contactor panel is switching load.

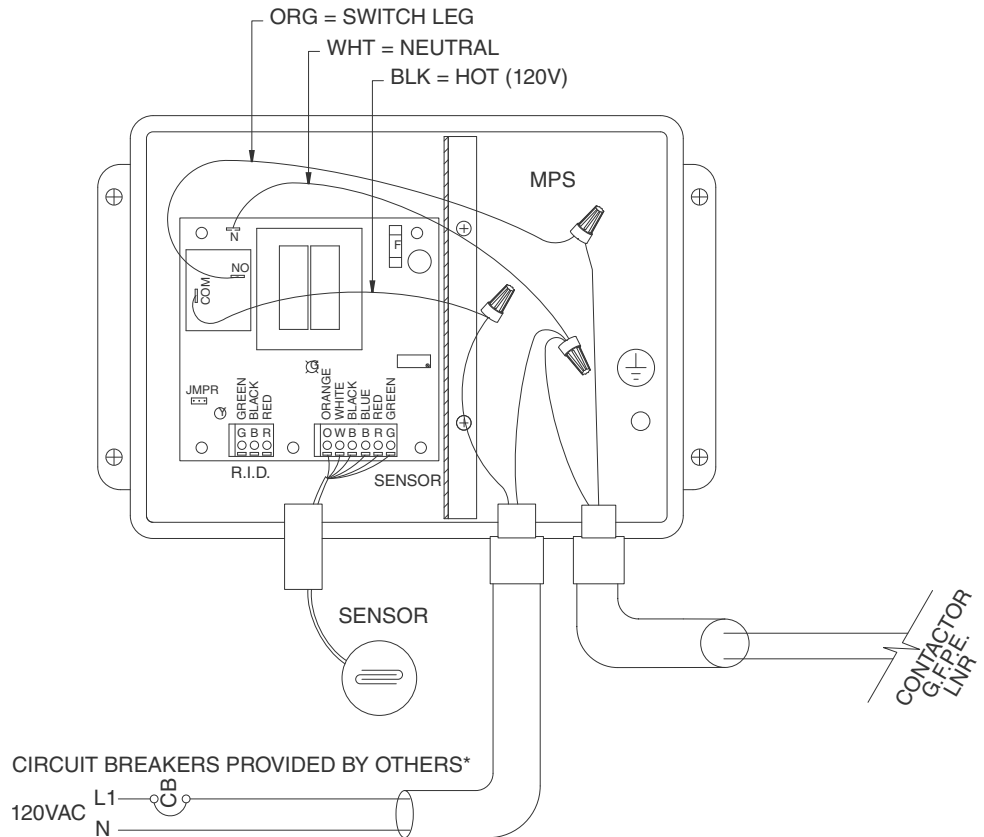

Detail 5. Electrical wiring when contactor panel is switching load.

Section 2. Installation

2.4 INSTALLING THE RG ROOF SENSOR

1. Place the RG sensor in the gutter using half of the supplied double-sided adhesive pad, directly under a drip loop. Do not locate the RG sensor under trees, awnings, next to a structure, or in any location which may be blocked from snow.
2. The MPS system arrives with the RG sensor attached to the MPS control panel with approximately 10' (3.04m) of sensor wire. To lengthen or shorten the sensor wire (press on the top of the terminal to release/insert wire):
 - Remove the six conductors of the sensor wire from the terminal block inside the control panel and loosen the sensor wire connector.
 - Gently pull the sensor wire through the wire connector and either cut to length as needed or splice on additional extension sensor wire in an appropriate junction box.*
 - Gently pull sensor wire back through the wire connector and reconnect the six conductors to the terminal block.
3. Wrap the remaining half of the adhesive pad around the Thermistor. The pad should adhere to itself. Stick the thermistor to the upper inside edge of the gutter. Do not allow the thermistor to touch the heating cable or any other heat source.

*NOTE: Select appropriate rated wire if exposed to sunlight (UV Inhibited) or route through a plenum air space.

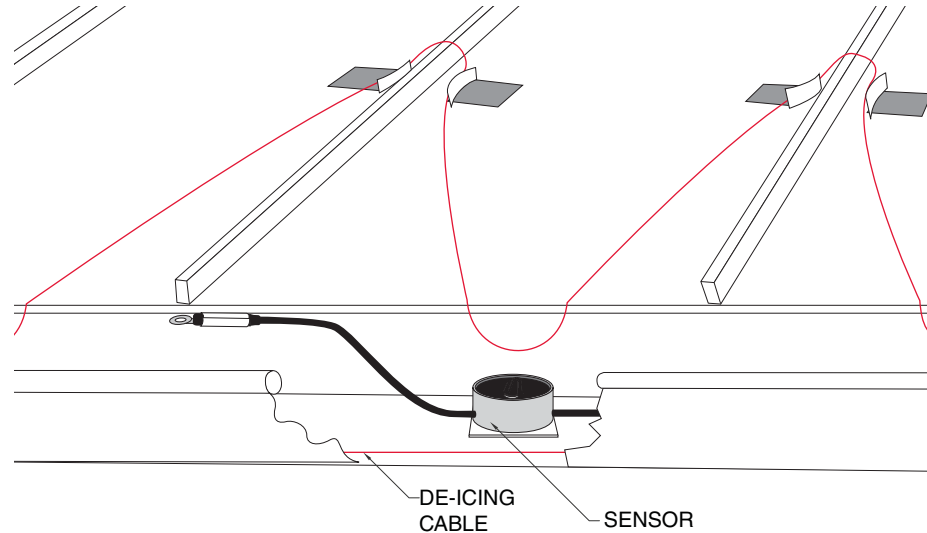

Detail 6. Installing the RG sensor in the gutter

Section 2. Installation

2.5 INSTALLING THE MP SLAB SENSOR

The MP sensor is mounted flush with the heated surface in an area most indicative of snow conditions. Do not locate the MP sensor under trees, awnings, where cars are parked, next to a structure, or in any location which may be blocked from snow.

The MPS system arrives with a MP sensor. Attach to the MPS control panel with approximately 10' (3.04m) of sensor wire. To lengthen or shorten the sensor wire (press on the top of the terminal to release/insert wire):

- Remove the six conductors of the sensor wire from the terminal block inside the control panel and loosen the sensor wire connector.
- Gently pull the sensor wire through the wire connector and either cut to length as needed or splice on additional extension sensor wire in an appropriate junction box.*
- Gently pull sensor wire back through the wire connector and reconnect the six conductors to the terminal block.

*NOTE: Select appropriate rated wire if exposed to sunlight (UV Inhibited) or route through a plenum air space

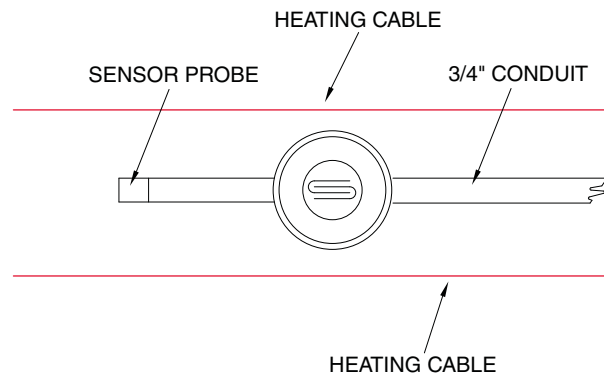

Detail 7. Plan view of a slab sensor.

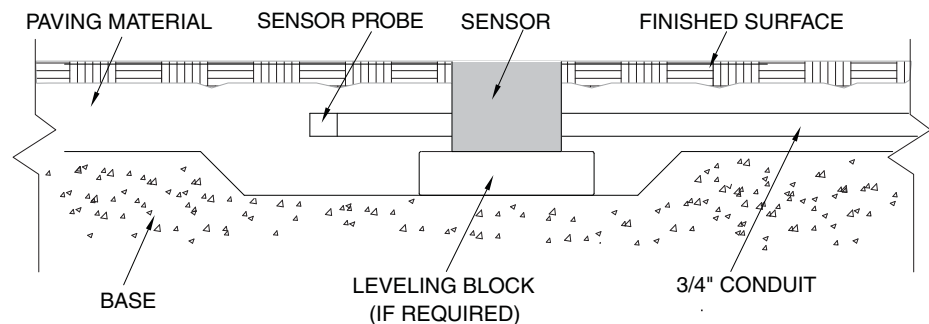

Detail 8. Side view of slab sensor.

Section 2. Installation

2.6 INSTALLING THE MMP SENSOR

1. Place the MMP sensor in the gutter or an area most indicative of snow conditions. Do not locate the MMP sensor under trees, awnings, next to a structure, or in any location which may be blocked from snow.

The MMP sensor can be attached to a junction box using the supplied .75" (19.05 mm) PVC conduit connector.

2. The MPS system arrives with the MMP sensor attached to the MPS control panel with approximately 10' (3.04m) of sensor wire. To lengthen or shorten the sensor wire (press on the top of the terminal to release/insert wire):
 - Remove the six conductors of the sensor wire from the terminal block inside the control panel and loosen the sensor wire connector.
 - Gently pull the sensor wire through the wire connector and either cut to length as needed or splice on additional extension sensor wire in an appropriate junction box.*
 - Gently pull sensor wire back through the wire connector and reconnect the six conductors to the terminal block.

*NOTE: Select appropriate rated wire if exposed to sunlight (UV Inhibited) or route through a plenum air space.

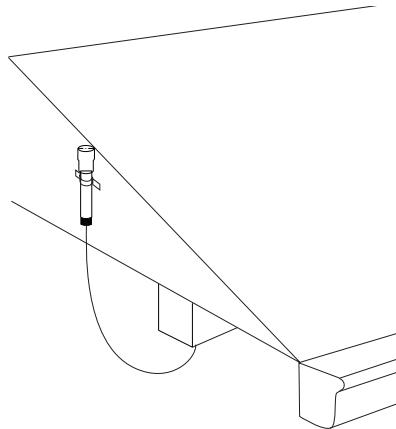

Detail 9. Installing the MMP sensor at roof level.

Section 2. Installation

2.7 INSTALLING THE RID

1. Drill a hole for a .5" (12.7mm) conduit fitting next to the RG sensor wire connector in the low voltage section of the MPS.
2. Install the .5" (12.7mm) conduit from the MPS to the RID junction box.
3. Install a low voltage three conductor cable or three insulated wires (22 awg minimum) from the MPS to the RID via the conduit.
4. Connect the red, green, and black wires of the RID to the R (red), G (green), and B (black) terminals of the MPS via the three installed conductors.

NOTE: The RID indicates de-icing/snow melting system activation and can communicate with the MPS to switch on the de-icing/snow melting system via the approximate 75 minute or 5 hour timer setting with the jumper on the back of the RID.

If the de-icing/snow melting system is activated by the sensor communicating with the MPS, the RID can not override the MPS to switch the de-icing system off.

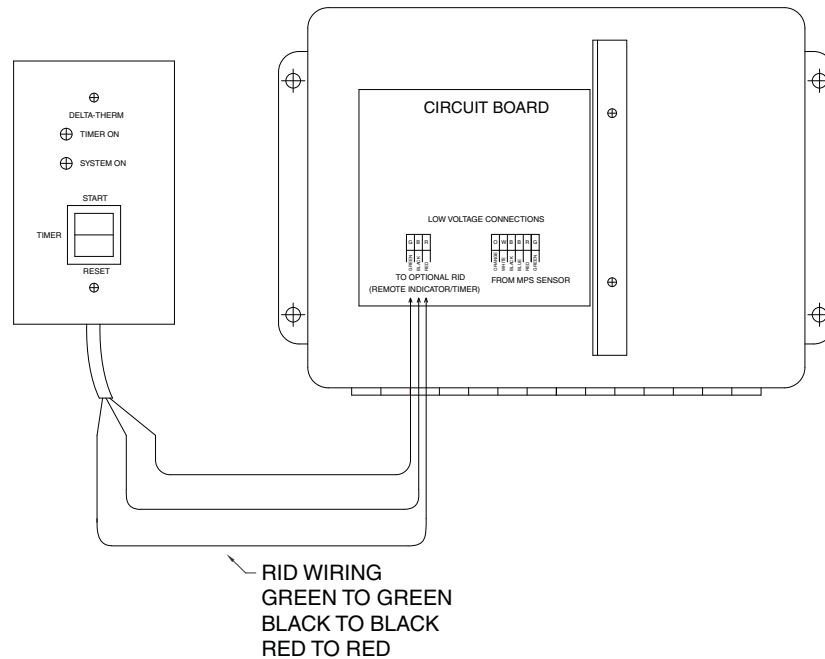

Detail 10. Installing the RID.

Section 3. Trouble-Shooting And Technical Support

3.1 MAINTENANCE

Clean the surface of the sensor before the start of each heating season with a brush or other means to remove dirt, grime, leaves, or debris that obstructs contact with snow or ice. Perform the system function check before the start of each heating season.

3.2 SYSTEM FUNCTION TEST

L1 LED light:

- When blinking indicates system readiness.
- When not blinking and L2 is lit indicates a wet RG sensor.

L2 LED Light:

- When lit indicates that the outdoor ambient temperature is below setpoint.
- When unlit indicates that the outdoor ambient temperature is above setpoint. To verify that power is wired correctly and timing sequence is working:
 1. Check that power is connected to the MPS control panel.
 2. Disconnect the red sensor wire from the terminal strip and verify that the L2 LED light is lit.
 3. Pour water on the RG sensor face to close the normally open contacts of the output relay on the internal circuit board and verify that the L1 LED light has stopped blinking.
 4. Dry the RG sensor and verify that the L1 LED light has restarted continuously blinking.
 5. To reset the output relay, remove power to the MPS.
 6. Reconnect the red sensor wire.
 7. Reapply power to the MPS.

3.3 TROUBLE-SHOOTING AND TECHNICAL SUPPORT

1. Verify there is 120 VAC across the red #10 AWG lead wire and the white #14 AWG lead wire inside of the MPS.
2. If switching 208 VAC or 240 VAC ensure a white neutral wire is pulled to the MPS

NOTE: For 208 VAC and 240 VAC the controller only switches one power leg, the other power leg (phase leg) passes through the device.

NOTE: Do not connect the white #14 AWG lead wire to any voltage, it is to be connected to neutral only.

3. Verify the color code of the RG sensor matches the terminal color code. Do the same if installing the optional RID device.
4. Verify all RG sensor and RID wiring is intact and ensure no open splices or damage to wire and cable.
5. Verify that the small plastic jumper on the main board is in the left position when installed for roof de-icing control and in the right position when installed for snow melting control (attached to left two pins/right two pins).

NOTE: If the jumper is not attached or present, the MPS will not turn off.

6. Remove the red sensor wire and apply moisture to the "U" shaped clips on the moisture sensor, verify the relay in the MPS energizes and switches power to the heating cable or contactor.
7. If the relay does not energize return the MPS to Delta-Therm. If the relay does energize, the system is functional.

For additional Trouble-Shooting Procedures, please contact Delta-Therm Technical Support for MPS Trouble-Shooting Manual.

If you have any questions or comments about these instructions, or your installation please call Delta-Therm between the hours of 8:00 a.m. - 5:30 p.m. CST, Monday through Friday at 1-800-526-7887.