



DTC120-PS

Wired to an LNR Panel

DTC120-PS is designed to detect snow or ice, and automatically activate contactors for snow melting cables or mats.

DTC120-PS INCLUDES:

1. DTC Control Panel
2. PS Slab Sensor
3. SS Slab Sensor
4. OTS-F1 Ambient Thermostat

OPTIONAL ITEMS:

5. RID (Remote Indicator and Activation Timer)
6. LNR Panel



WARNING: This device must be installed by a qualified electrician. All assembly, installation, and test instructions must be followed. Improper installation can result in property damage, serious injury, and/or death due to electric shock. Call Delta-Therm at 1-800-526-7887 with any installation or operating questions.

Finished Install

NOTE: The National Electrical Code (NEC) requires 30mA Ground Fault Protection Equipment (GFPE) on this system. Check with all local codes prior to installation.

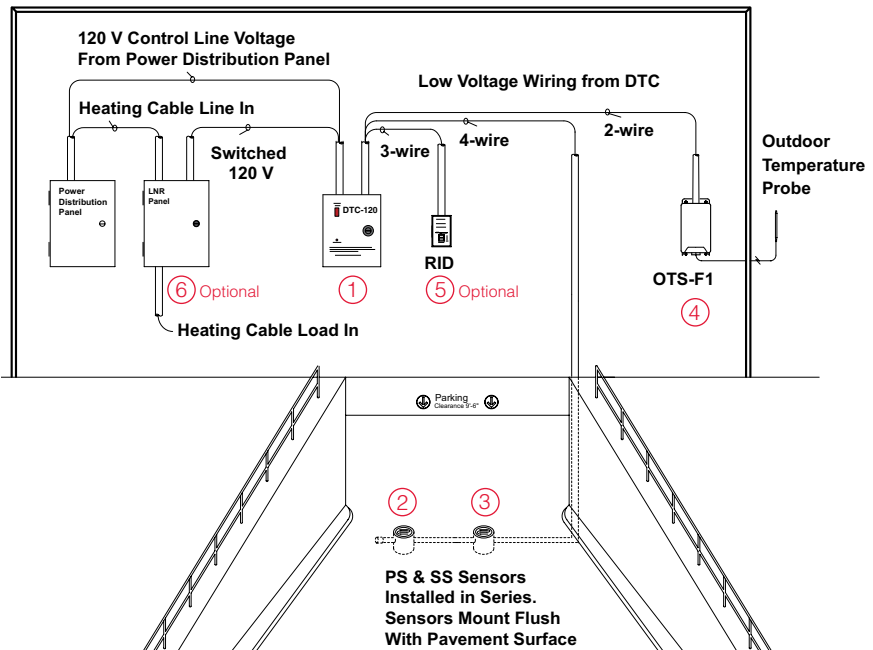

DELTA-THERM.COM

DELTA-THERM Corp., P.O. Box 345, Wauconda, IL 60084 (800) 526-7887 Fax (847) 526-4456



leaders in engineered heat trace

3

Wiring the PS and SS Sensors

- black ——— TB3
- red ——— TB4
- yellow ——— TB5
- green ——— TB6

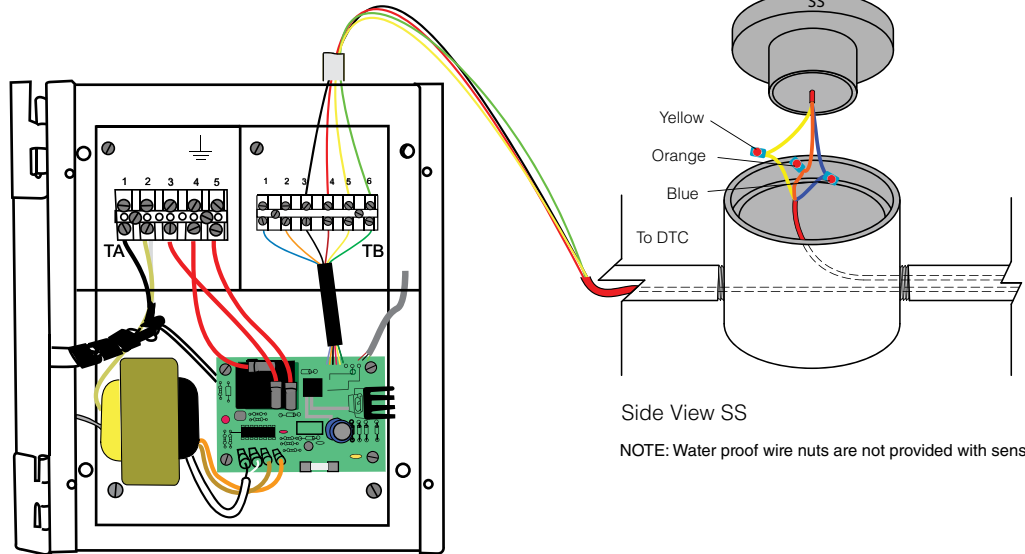

Side View SS

NOTE: Water proof wire nuts are not provided with sensors.

4

Wiring OTS-F1

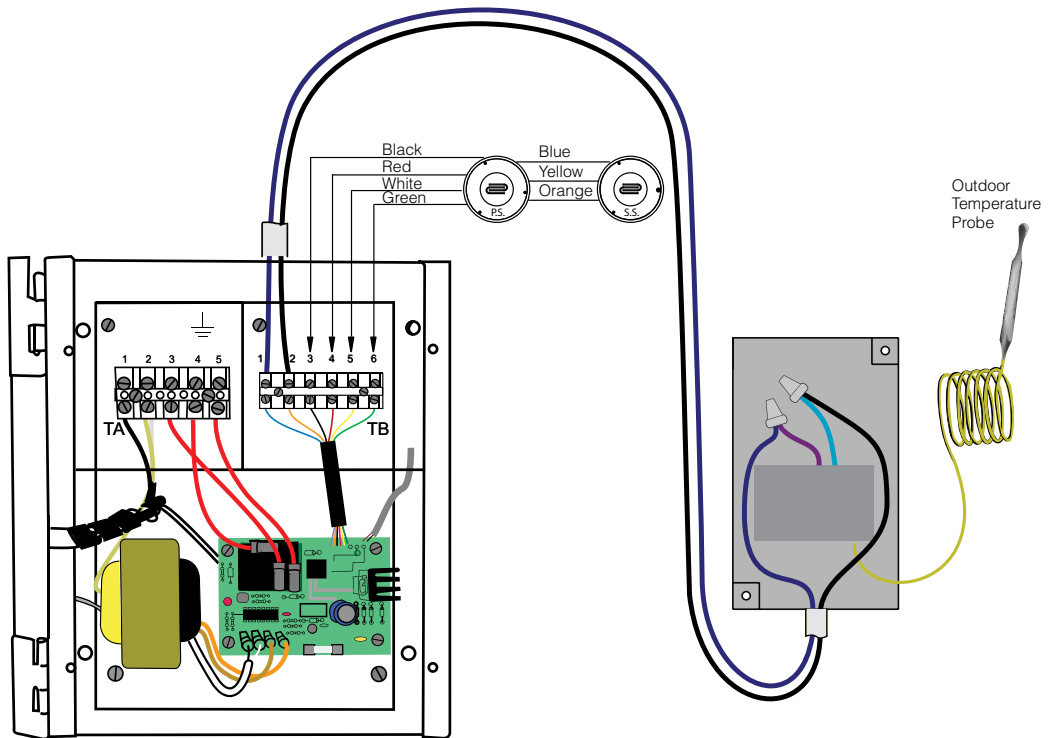



5

Wiring DTC120-PS to an LNR Panel

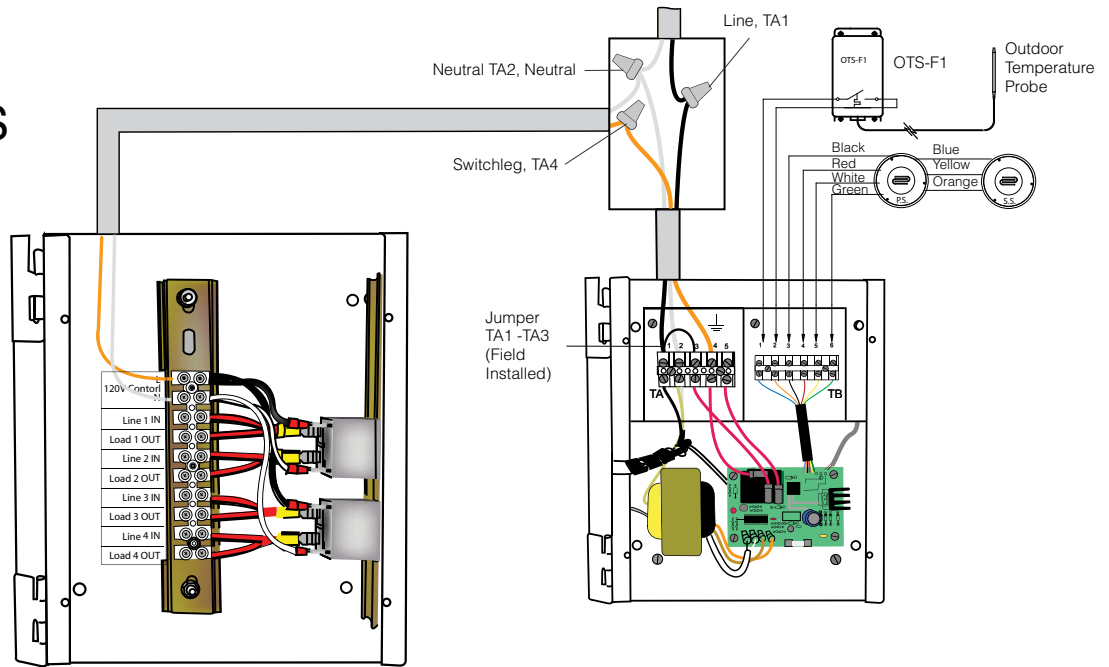

6

Installing and Wiring RID

