

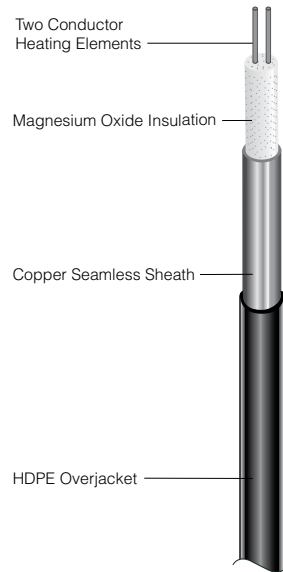

MINERAL INSULATED (MI) HANGAR DOOR RAIL DEICING CABLE ASSEMBLY



One Conductor And Two Conductor



DESCRIPTION

Mineral insulated (MI) cable for hangar door rail deicing applications consists of a two conductor heating element embedded in highly compressed magnesium oxide covered by a seamless copper sheath and a high density polyethylene overjacket. Application requirements determine resistance size.

TERMINATION CONSTRUCTION

Each Delta-Therm M.I. cable assembly is fully terminated and moisture proof. The end termination consists of a 2.5' (76cm) thermal gradient section connected to 20' (6m) THWN cold leads. The cold leads are crimped and soldered to the thermal gradient section, insulated with a high-dielectric, high-temperature tape, and epoxy potted in a rigid brass sleeve. The thermal gradient section is silver soldered to the heating element and protected by a rigid brass sleeve packed with magnesium oxide.

COLD LEADS

The 19-strand THWN wire connects to an electrical circuit. Standard cold lead length is 20' (6m). Leads can be ordered at any length, allowing junction boxes to be placed in remote, dry locations.

NUMEROUS VOLTAGES

Delta-Therm can design M.I. snow melting cable assemblies for any voltage up to 600 volts.

FLEXIBLE

M.I. cable is annealed (annealing tempers metal and removes brittleness) and easy to form and install. Irregular areas and obstacles are easily accommodated.

PAVING MATERIALS

M.I. cable can be embedded in concrete, in asphalt, and in sand under pavers.

HDPE JACKETING

Extruded, high-density polyethylene jacketing adds physical strength and protects against corrosives such as calcium chloride and salt.

FIRE RESISTANT

M.I. cable construction will not contribute to or cause an electrical fire.

NO DEGRADATION

Delta-Therm M.I. cable is made of inorganic materials. Degradation of M.I. cable is negligible when compared to cables made of organic materials such as plastic.

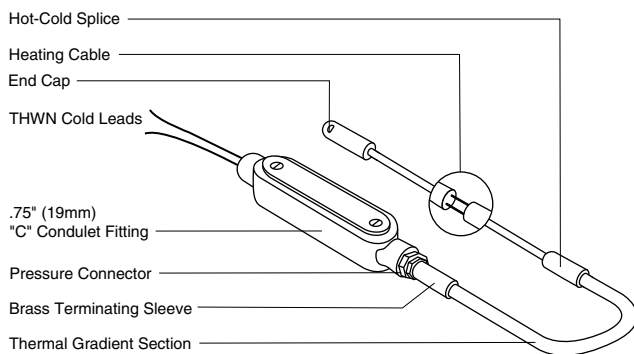

Detail 1. Two Conductor Cable Assembly



COMPREHENSIVE FACTORY TESTING

Each cable undergoes hi-pot, megger, and resistance tests both before and after overnight immersion in water.

LOW INSTALLATION COSTS

MI cable arrives ready to install. Since terminations are done at the factory, electricians can expedite the installation, helping to reduce overall installation costs.

Recommended Watts Per Lineal Foot And Cable Spacing

Area	Watts	Centers
Hangar Door	25	Attach To Outer Bottom (Rail Deicing) Flange Of Rail

Material Temperature Limits

HDPE Overjacket °F (°C)	194** (90°)
Copper °F (°C)	392° (200°)

*HDPE overjacketed cable may be exposed to higher temperatures during installation in asphalt.

Cold Lead Size

Amps	Wire Size
0-16	12 AWG
16-24	10 AWG
24-45	8 AWG
45-65	6 AWG

BASE KIT (supplied with each MI cable assembly)

- Thermal Gradient Section
- Cold Leads
- Pressure Connectors
- "T" Or "C" Condulet With Gasket And Cover
- Delta Dry (Water Repellent Powder)
- Duct Seal
- Installation Instructions

Base Kit Accessories

Heater Assembly Only
Additional 19-Strand Cold Lead
Base Kit
Splice Kit
Unilet Kit
Additional Thermal Gradient

Controls

DTC-24S	Automatic Snow Melt Control
DTC-24A	Automatic Snow Melt Control
MPS	Automatic Snow Melt Control

Panels

DT-XXPXXX	Enclosed Contactor
GFPE-X-X	Power Control Panel w/GFPE
LNR-X	Low Noise Relay Panel
Custom Control/Monitor/Alarm Panels	

Accessories

T-SSS	Stainless Steel Strapping
NEC Plaque	Embedded Heating System's Marker

INVENTORY AND SHIPPING

Delta-Therm maintains an inventory of both bare and jacketed mineral insulated cable. Orders of material in stock can usually be shipped within two weeks.

TO ORDER:

Prefix (H - Hangar Door Rail Deicing)	_____
Number Of Conductors	_____
Ohms/Ft. (m)	_____
Length Per Hot Section	_____
Volts	_____
Amps	_____
kW	_____
Watts Per Lineal Foot (refer to design guide)	_____
Suffix H, B, Or SS (if desired)	_____
AWG (refer to chart)	_____
Cold Length (length needed to reach junction box NOTE: voltage drop not to exceed 3%)	_____