

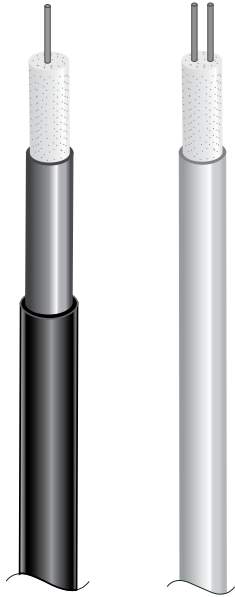

Installation Instructions

MINERAL INSULATED (M.I.) TANK TRACE CABLE ASSEMBLY



CONTENTS	page
SECTION 1. OVERVIEW	
1.1 Precautions.....	2
1.2 Cable and components	2
1.3 General accessories	3
1.4 Tools recommended	3
1.5 Site plan	3
1.6 Cable storage	3
1.7 Cable labeling	3
1.8 Cable testing.....	4
1.9 Site preparation	4
1.10 Proper cable handling	4
1.11 N.E.C. code	4
1.12 Conduit and circuit wire	4
SECTION 2. INSTALLATION	
2.1 Installation.....	5
SECTION 3. TESTING AND TROUBLE-SHOOTING M.I. CABLE	
3.1 Pre-installation testing	6
3.2 Monitoring cable during installation	6
3.3 Final testing.....	6
3.4 Maintenance	6
3.5 Trouble-shooting and technical support	6



Warning: Mineral Insulated cable must be installed by a qualified electrician. All assembly, installation, and test instructions must be followed. Improper installation can result in property damage, serious injury, or death due to electric shock. Please call Delta-Therm Corporation at 1-800-526-7887 with any installation or operating questions.

Section 1. Overview

1.1 PRECAUTIONS

- Installation in accordance with the National Electric Code and local electrical codes.
- Do not bend cable within 3" of a termination.
(Terminations labeled DO NOT BEND HERE)
- Do not bend cable tighter than 3" inside diameter.
- Do not twist, kink, or spiral the cable.
- Do not pull cable from coil. Roll coil to unreel cable.
- Test the Mineral Insulated M.I. cable assemblies before installation with a 500 VDC insulation resistance tester and multimeter (ohm meter).
- Do not overlap heating cable.
- Cables for classified areas should be tagged for specific classifications.
- All related components and controls should be properly rated for the specified location classification.
- Do not alter the Mineral Insulated M.I. tank trace cable assemblies length in the field, as this will damage the system and void all warranties.
- Minimum installation temperature is -20°C
- The metal sheath of the M.I. cable needs to be bonded to a suitable earth terminal.
- Leave all tags on the cables as they include the listings and electrical requirements.
- All systems must be installed in accordance with the prevailing electrical code.

1.2 M.I. CABLE AND COMPONENTS

Each M.I. tank trace cable assembly is factory terminated. Each M.I. cable assembly unit includes one base kit. Each base kit includes:

- (1) .75" conduit body (C or T type)
- (1) Bag of Delta Dry hydroponic powder
- (1) Piece of duct-seal
- Required pressure connector(s)

Each M.I. tank trace cable assembly has a UL or CSA label attached to the THWN cold lead within 3" of the brass terminating sleeve stating in order:

1. Cable type prefix
2. Number of conductors
3. Cable resistance
4. Cable length in feet
5. Operating voltage
6. Current draw
7. Total wattage
8. Watts per lineal foot

Note: Do not remove the UL or CSA label.

Section 1. Overview

1.3 GENERAL ACCESSORIES

Accessories

Product Number	Description
PCK-TT, PCK-C6, PCK-IN, PCK-HT, PCK-HLC	Power Connection Kits for self-regulating cables. Please consult datasheet to verify that you are using the listed kit for your cable.
ETK-IN, ETK-HT	End Termination Kits for self-regulating cables. Please consult datasheet to verify that you are using the listed kit for your cable.
SPK-IN	Splice Connection Kit for self-regulating cables. Please consult datasheet to verify that you are using the listed kit for your cable.
CL-S/CL-L	Small And Large Caution Labels
DT-Box	Weatherproof 2 Gang Aluminum Box With Five .75" (2cm) Hubs And Cover
PC1, PC2	Weatherproof 2 Gang Polycarbonate Boxes.
T-ALXXX	Aluminum Heat Distribution Tape
T-FXXX	Fiberglass Banding Tape

Panels

Product Number	Description
DT-XXPXXX	Enclosed Contactor Panel
GFPE-X-X-X	Power Control Panel w/GFPE
LNR-X	Low Noise Relay Panel
Custom Control/Monitor/Alarm Panels	

Controls

Product Number	Description	Product Number	Description
Master Trace	Multi-circuit load switching thermostat device with monitoring & line sensing	OTS-4A	Adjustable Ambient Sensing Thermostat in NEMA 4, 7, 9 Enclosure
Trace Mates	Single and dual circuit load switching thermostat device with monitoring & line sensing	A419ABC-1C	Adjustable Line or Ambient Sensing Thermostat With Key Pad and LCD Display in NEMA 1 Enclosure
PowerTrace etc1	Single circuit load switching thermostat device with monitoring & line sensing	A419AEC-2C	Adjustable Line or Ambient Sensing Thermostat With Key Pad and LCD Display in NEMA 4X Enclosure
OTS-F1	Fixed Ambient or Line Sensing Thermostat in NEMA 4X Enclosure	A19ABC-24	Adjustable Line Sensing Thermostat in NEMA 1 Enclosure
OTS-1A	Adjustable Line Sensing Thermostat in NEMA 4X Enclosure	A19ANC-1C	Adjustable Line Sensing Thermostat in NEMA 3R Enclosure
OTS-2A	Adjustable Ambient Sensing Thermostat in NEMA 4X Enclosure	E55-E21BSS	Adjustable Line Sensing Thermostat NEMA 4 Enclosure
OTS-3A	Adjustable Line Sensing Thermostat in NEMA 4, 7, 9 Enclosure		

1.4 TOOLS REQUIRED

- 500 VDC insulation resistance tester
- Flat head screwdriver
- Digital multimeter
- Fish tape
- Clamp-on ammeter
- Adjustable wrench

1.5 SITE PLAN

Delta-Therm offers engineered drawing services as outlined in our Price List. If drawings were ordered, please compare the drawing bill of materials to materials supplied with your order and verify that you received all of the Delta-Therm components. Before starting the installation verify the proper location and layout of heating cable(s), control(s), and/or accessories.

1.6 CABLE STORAGE

All M.I. tank trace cable assemblies should be stored in a cool, dry location. Cables should be protected from damage. Following the cable testing instructions in section 4, test all cables removed from storage and record the readings on the warranty card.

1.7 CABLE LABELING

Delta-Therm Mineral Insulated M.I. tank trace cable assemblies are UL listed and CSA certified for tank trace installations. Each M.I. cable has a UL or CSA label attached to the THWN cold lead within 3" (76mm) of the metal sleeve. The label states the following information in order: cable type (prefix, number of conductors, and cable resistance), cable length, operating voltage, current draw, total wattage, watts per lineal foot, and cold lead length. Cold leads are sized to current draw. DO NOT REMOVE THIS LABEL. The cable has a standard THWN cold length of 10' (3m).

Section 1. Overview

1.8 CABLE TESTING

Please refer Section 3 for all cable testing procedures.

1.9 SITE PREPARATION

Review installation, engineering, electrical, and or architectural drawings prior to installation. Install conduit from the cable feed points to an indoor or dry junction box, continuing to the power panel per site plan. Install appropriate grounding system per prevailing electrical code.

Verify that available voltage is the same as the cable operating voltage indicated on the UL or CSA label. Tanks should be pressure tested for leaks. The vessels should then be cleaned of any dirt or corrosive materials, and dried. Pre-punched stainless or galvanized steel strapping can be attached to the tank using guide wires or welded-on studs. Provide power within 4' of the start of the tank trace.

1.10 PROPER CABLE HANDLING

Always unroll the coil of M.I. cable. Do not pull the cable in a helix fashion.

1.11 NEC CODE

Please refer to: NEC Section Article 427 Fixed Electric Heating Equipment for Pipelines and Vessels.

1.12 CONDUIT AND CIRCUIT WIRE

The cable assemblies require a permanently wired and grounded conduit system. Use only UL Listed (CSA Certified) weatherproof junction boxes.

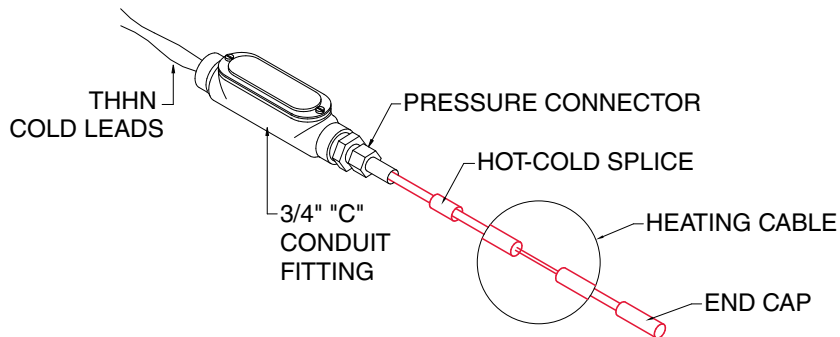

Detail 1. Dual conductor M.I. tank trace cable assembly is typically installed on vertical tanks. The assembly is factory terminated and ships with a base kit as described in section 1.2.

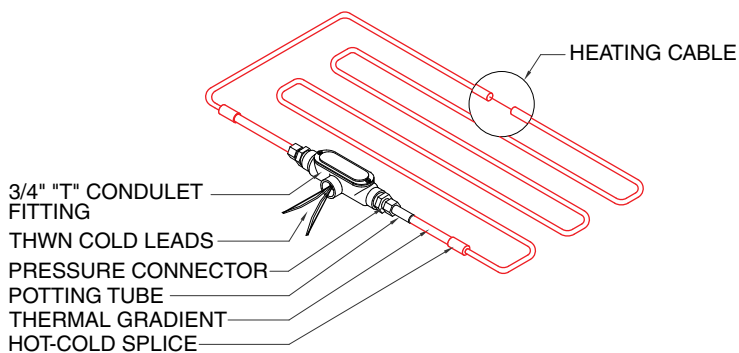

Detail 2. Single conductor M.I. tank trace cable assembly is typically installed on horizontal tanks. The assembly is factory terminated and ships with a base kit as described in section 1.2.

Section 2. Installing M.I. cable on vertical and horizontal tanks

2.1 INSTALLATION

Before starting the installation please refer to Section 1.5 Site Plan, Section 1.9 Site Preparation, and test cables following the directions in Section 3.1 Pre-Installation Testing. Please refer to Detail 1 and Detail 2 to review single and dual conductor cable finished assembly and base kit components.

The cable will be positioned on the lower 1/3 portion of the tank. Install the cable as indicated in Detail 2, Detail 3 or according to the engineering drawings. Run the cable out from the conduit body (CB) in a serpentine pattern around the tank.

Single conductor cable uses a T-type CB and dual conductor cable uses a C-type CB. The end of a single conductor cable must return to a 3/4" CB. Dual conductor cable will end on the tank.

Cables can be covered with T-AL200 or T-AL400 aluminum heat transfer tape for more efficient heat transfer.

1. Install the CB within 4' of the tank to be heated. Place the junction box within 4' of CB. Install 3/4" pressure fittings into CB, and pull one cold lead through a pressure connector until the metal sleeve is halfway into CB. With dual conductor cables pull both cold leads.
2. Tighten the pressure fitting on to the sleeve and uncoil the cable.
3. Attach cable to tank using pre-punched galvanized or stainless steel strapping. Start at the hot to cold junction and work back, uncoiling carefully. Do not bend the cable within 3" of the hot to cold junction. Do not unreel the cable like building wire. For single conductor cable, install the second end into the CB and tighten the pressure connector.
4. Pull the cold leads through conduit into junction box.
5. Install controls and insulate according to specification.

NOTE: Use 3/4" rigid metal conduit for grounding. Install duct seal into the 3/4" opening between the CB and the conduit. Fill the CB with Delta-Dry powder, and seal with a gasket and cover. Do not remove the UL or CSA label from the cable.

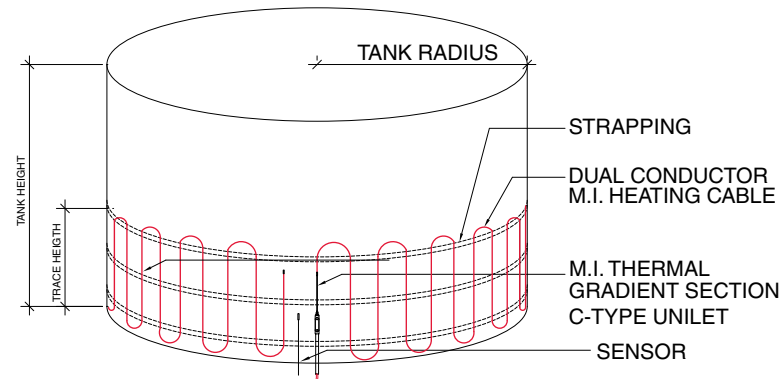

Detail 3. Vertical tank trace with dual conductor M.I. cable.

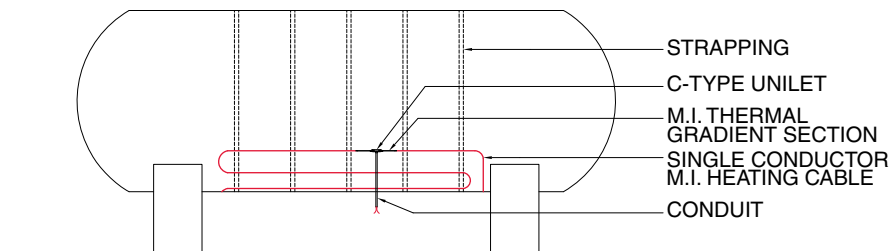

Detail 4. Horizontal tank trace with single conductor M.I. cable.

Section 3. Testing and Trouble Shooting

3.1 PRE-INSTALLATION TESTING

Unpack the M.I. cable and test each cable for insulation resistance (IR), and total resistance (TR).

To test TR, connect each lead of the ohmmeter to each M.I. cable cold lead conductor. Test in accordance with the meter manufacturer's instructions. Compare TR reading from ohmmeter to calculated TR (multiply the heated length of cable by the cable resistance value found on UL/CSA label). The ohmmeter reading should be within 10% of the calculated TR.

To test IR, connect one lead of the 500 VDC insulation resistance tester to one cold lead conductor and the other lead to the M.I. cable metal sheath. Test in accordance with the meter manufacturer's instructions. IR reading should be greater than 10 megohms.

Please enter the TR and IR readings on the warranty card.

3.2 MONITORING CABLE DURING INSTALLATION

Repeat the steps as described in Section 3.1 and enter the information on the warranty card. If there is a change in the meter reading, please check the cable for damage, as well as any power connections, splices, and end terminations.

3.3 FINAL TESTING

Repeat the IR test steps as described in Section 3.1. To test TR, connect each lead from the ohmmeter to the two cold leads that will be attached to power. Enter the information on the warranty card. If there is a change in the meter reading, please check the cable for damage, as well as any power connections, splices, and end terminations.

3.4 MAINTENANCE

Annually check system for loose or damaged cable.

3.5 TROUBLE-SHOOTING AND TECHNICAL SUPPORT

If during any test the meter readings vary by +/- 10% from the previous test, stop the installation and investigate. Please check for pinched or crushed cables, test splices, test power connections, test end terminations, and repair accordingly. Check for water in all junction boxes or conduit. Any faults should be repaired by a qualified electrician or factory technician before the final pour is made.

For additional trouble-shooting and repair procedures, please contact Delta-Therm technical support at 1-800-526-7887. Please be prepared to provide:

- Part numbers for all installed equipment
- IR and TR readings on all installed cables
- Verification that incoming voltage matches design voltage of Delta-Therm equipment
- Verification that you have checked all wiring, junction boxes, etc.
- Digital photos of installed equipment

If you have any questions or comments about these instructions or your installation please call Delta-Therm at 1-800-526-7887.